

Savage Classic Rotax 912 ULS Flight Manual

**Manufactured By:
Zlin Aviation s.r.o.
2. kvetna n. 685
763 61 Napajedla
Czech Republic**



**Serial Number:
Registration Number:**

Intentionally left blank

1 Table of Contents

1 Table of Contents.....	3
2 Amendment Record Sheet.....	5
3 General.....	6
3.1 Introduction.....	6
3.2 Revisions.....	6
3.3 Definitions.....	6
3.4 Terminology.....	7
4 Airplane and Systems Description.....	8
4.1 Three View Drawing.....	8
4.2 Descriptive Data.....	8
4.3 Specifications.....	9
5 Limitations.....	12
5.1 Introduction.....	12
5.2 Type of Operation.....	12
5.3 Airspeed Limitations.....	12
5.4 Maximum Weights.....	12
5.5 Power Plant Limitations.....	12
5.6 Other Limitations.....	12
6 Weight and Balance.....	14
6.1 Introduction.....	14
6.2 CG Data.....	14
6.3 CG Calculations.....	14
6.4 Equipment List.....	15
6.5 CG Work Form.....	16
6.6 Method.....	17
7 Performance.....	18
7.1 Stalls.....	18
7.2 Takeoff and Landing Distances.....	18
7.3 Maximum Crosswind Component for Takeoff.....	18
7.4 Cruising Flight at sea level.....	18
7.5 Service Ceiling.....	18
7.6 Climb.....	19
7.7 RPM.....	19
7.8 Fuel Consumption.....	19
8 Emergency Procedures.....	20
8.1 Introduction.....	20
8.2 Airspeeds for Emergency Operation.....	20
8.3 Engine Failures.....	20
8.4 Airstart Procedures.....	21
8.5 Fires.....	21
8.6 Precautionary and Forced Landing.....	22

8.7 Other Procedures.....	23
9 Normal Operations.....	25
9.1 Introduction.....	25
9.2 Normal Operating Speeds.....	25
9.3 Checklist and Procedures.....	26
9.4 Taxi Procedures.....	29
9.5 Takeoff.....	30
9.6 Landing Procedures.....	31
10 Aircraft Handling and Servicing.....	34
10.1 Fueling Safety Precautions.....	34
10.2 Filling the Fuel Tanks.....	34
10.3 Propeller Care.....	34
10.4 Securing the Airplane.....	34
10.5 Noise Abatement.....	35
10.6 Engine Shutdown.....	35
10.7 Starting the Engine from an External Power Source.....	35
11 Required Placards and Markings.....	36
11.1 Airspeed Indication Range Markings.....	36
11.2 Passenger Warning.....	36
11.3 Aerobatic Statement.....	36
11.4 Spin Statement.....	36
12 Supplemental Flight Training Information.....	37
12.1 Design Philosophy.....	37
12.2 Revisions.....	37
12.3 Other Landing Gear.....	37
12.4 Ground Transport.....	37
12.5 Other Equipment Necessary for Flight.....	37
12.6 Engine Differences.....	37
12.7 Engine Mount.....	37
12.8 Landing Flap Takeoffs.....	38
12.9 Side Slips.....	38
12.10 Emergency Checklists.....	38
13 Feedback Form.....	40
14 Malfunction or Defect Report Form.....	42

3 General

3.1 Introduction

This Flight Manual applies only to the particular aircraft identified by the registration marking and serial number on the title page and contains the airworthiness limitations and essential operating data for this aircraft.

The Flight Manual shall be carried in the aircraft on all flights.

The pilot in command of the aircraft shall comply with all requirements, procedures and limitations with respect to the operation of the aircraft set out in the Flight Manual for the aircraft.

Amendments shall be issued by Zlin Aviation s.r.o. as necessary and will take the form of replacement pages, with the changes to the text indicated by a vertical line in the margin together with the amendment date at the bottom of the page.

Interim and/or Temporary amendments may be issued in the same manner and are to be inserted as directed. These amendments will be issued on colored pages and will take precedence over the stated affected page. It is the owner's responsibility to incorporate in this manual all such amendments, and to enter the date of incorporation and his signature on the appropriate Amendment Record Sheet.

No entries or endorsements may be made to this Flight Manual except in the manner and by persons authorized for the purpose.

3.2 Revisions

It is the responsibility of the owner to maintain this manual in a current status when it is being used for operational purposes.

Owners should contact Zlin Aviation s.r.o. whenever status of their manual is in question.

All revised pages will carry the revision number and the date on the amendment record sheet. (Page 7)

3.3 Definitions

Standard Atmosphere	Standard Atmosphere is the pressure at sea level (29.92in Hg) at 15°C (59°F). The standard lapse rate is approx. 1in Hg and 2°C (3.5°F) per 1000ft increase in altitude.
Airport Pressure Altitude	The altitude observed on the altimeter when the barometric subscale is set to 29.92in Hg (1013mbar).
Density Altitude	The Pressure Altitude corrected for non standard temperature.
Takeoff Flaps	Produce more lift than drag.
Landing Flaps	Produce more drag than lift.
IAS	Indicated Airspeed, the airspeed shown on the airspeed indicator, uncorrected.
V_a	Maneuvering Speed, the maximum airspeed at which the limit load can be imposed either by gusts or full deflection of the flight controls without causing structural damage.
V_{fe}	Maximum Flap Extended Speed, the maximum speed permitted with flaps extended.
V_{no}	Maximum Structural Cruising Speed, at which to be operated only in smooth air with caution.
V_{ne}	Never Exceed Speed.
V_{so}	Stalling Speed, the minimum steady flight speed in the landing configuration MTOW.*
V_x	Best Angle of Climb, the airspeed which results in the most altitude gain in a given distance .
V_y	Best Rate of Climb, the airspeed which results in the most altitude gain in a given length of time .

*without vortex generator installed

3.4 Terminology

3.4.1 Meteorological Terminology

Outside Air Temperature	The free static air temperature. It is expressed in either degrees Celsius or degrees Fahrenheit.
Standard Temperature	Standard Temperature is 15°C at sea level pressure altitude.
Pressure Altitude	The altitude read from the altimeter when the altimeter's barometric scale has been set to 29.92in Hg (1013mbar).

3.4.2 Engine Power Terminology

BHP (Brake Horse Power)	The power developed by the engine.
RPM (Revolutions Per Minute)	Engine speed.
Static RPM	The engine speed attained during a full throttle engine run-up when the airplane is on the ground and stationary.

3.4.3 Flight Performance Planning Terminology

Maximum Crosswind Component	The maximum demonstrated crosswind component that provides adequate control of the airplane during takeoff and landing was conducted during certification tests. The value shown is limiting. Demonstrated 18mph (15kts)
Useable Fuel	The fuel available for flight planning.
Unusable Fuel	The quantity of fuel that cannot be safely used in flight.
GPH	Gallons per hour, The fuel amount in gallons consumed per hour.
NMPG	Nautical Miles per Gallon, the distance traveled in nautical miles per one gallon of fuel consumed at a specified power setting.
g	The acceleration due to gravity.

3.4.4 Weight and Balance Terminology

Station	Only three load stations are specified: Seat Station, which is the center of the fixed seats; Fuel Station, which is the center of the fixed fuel tank; and the Baggage Station.
C.G. (Center of Gravity)	The C.G. is the point at which an airplane would balance if suspended.
C.G. Limits	The extreme limits of gravity locations within which the airplane must be operated at a given weight.
Standard Empty Weight	The weight of a standard airplane including unusable fuel and all engine operating fluids full.
Basic Empty Weight	The standard empty weight plus the weight of optional equipment.
Useful Load	The difference between ramp weight and the basic empty weight.
MTOW	Maximum Takeoff Weight, the maximum weight approved for the start of the takeoff run.

4 Airplane and Systems Description

4.1 Three View Drawing

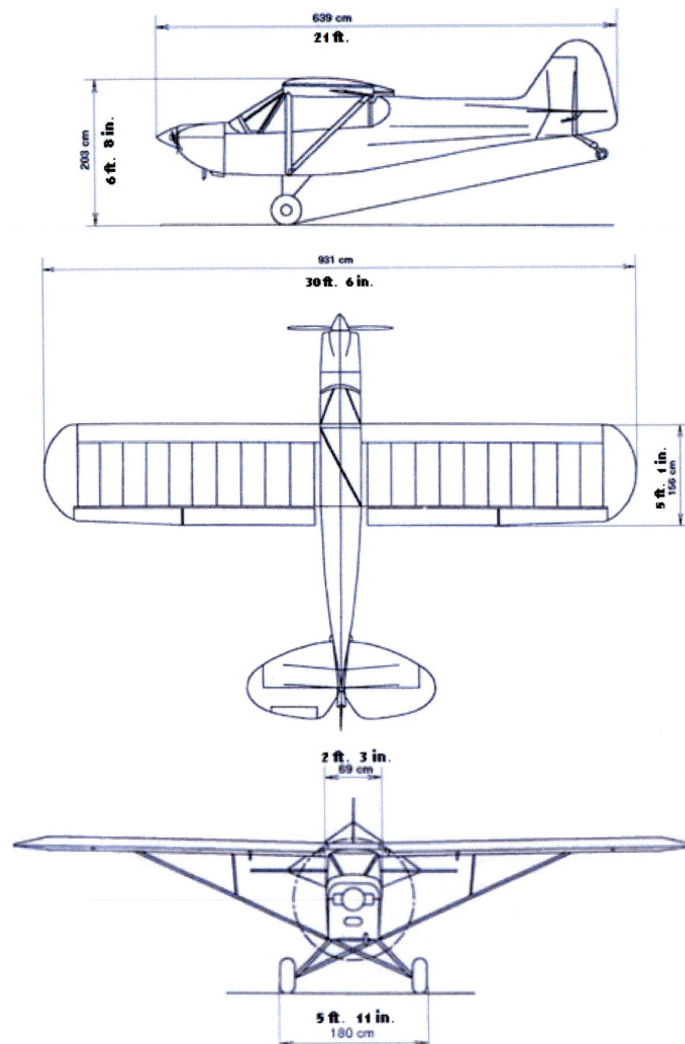

4.2 Descriptive Data

4.2.1 Engine

The Engine is a ROTAX GmbH Aircraft Engine, Type 912ULS Liquid Cooled Series.

*Please refer to the Rotax manual for the most recent updates on correct use of the engine.

4.2.2 Propeller

The Propeller is a Tonini Fixed Pitch Wooden GT-130/135.

4.2.3 Approved Fuel Types and Grades

Approved fuel types and grades:

See the engine manual

Fuel Capacity Indicators: Clear-view type mounted on each tank.

4.2.4 Fuel Capacity

Total	18 Gallons (between two 9 gallon wing tanks)	68 Liters
Useable	17 Gallons	64.5 Liters

4.2.5 Approved Oil Grades

See the engine manual

4.2.6 Oil Capacity

See engine manual.

4.2.7 Tire Inflation Pressures

Main Standard Tire	16psi	1.10bar
Tundra Tire (optional)	13psi	0.9bar
Tailwheel	32psi	2.2bar

4.3 Specifications

4.3.1 Specification Table

Dimensions		Performance	
• Wing Span	30ft 6in	• Vne	128 mph(111 kts)
• Length	21ft	• Max Speed straight & level	117 mph (101 kts)
• Height	6ft 8in	• Cruising Speed 75%	104 mph (90 kts)
• Wing Surface Area	153 sq ft	• Climb Rate	866 ft/min
• Wing Cord	5ft 2in	• Stall Speed w.f. MTOW*	38 mph (33 kts)
• Cabin Width	2ft 6in	• Max Ceiling	14,400ft
• Wheel Tread	5ft 6in	• Range 65%	447mi
Weights		• Required Takeoff Space	361ft
• Max Takeoff Weight	1235 lbs	• Required Landing Space	295ft
• Stand. Empty Weight	669 lbs	• Required Landing Space w/50ft Obstacle	623ft
• Payload	566 lbs		
• Max Wing Loading	8.07 lbs sq ft		
• Load Factor	+6-3		

*without vortex generator installed

4.3.2 Technical Description

The Savage is a single engine, high wing, two seat tandem Light Sport Aircraft of classical design. It is built in the Czech Republic in full compliance with the regulations in force in that country, and to the requirements of the ASTM Consensus Standards for Light Sport Aircraft.

4.3.3 Fuselage

The Fuselage consists of a true space framed designed structure made up of TIG welded 4130 aeronautical steel tubing. All welds are visually inspected and further checked with the aid of penetrant liquids. As an option tubes may be further protected against corrosion with an oil-based internal coating. Access to the cockpit is gained via a single door on the right side of the fuselage that opens upward. The cockpit provides ample space for the pilots. Good visibility and ergonomic seats and controls make flying comfortable and safe even over long distances. Type approved 4 point seat belts increase the overall sensation of safety provided by the savage. The fuselage is covered with a 3.6oz polyfiber fabric which is treated and finished with polyurethane paint.

Windshield and windows are made of Lexan F 5006. The Savage features a complete set of dual controls except for the flap and trim controls. There is an ample storage compartment behind the passenger seat.

4.3.4 Wings

The wings are of the rectangular type with rounded wing tips. The airfoil is a modified 4412. The structure is made up of two tubular spars in aeronautical aluminum alloy (doubled on the inside where necessary) and a classically designed system of compressors and diagonals. Each wing consists of 10 bays and a wing tip and 11 ribs attached to the structure and sewn to the fabric skin. Each wing root contains a welded aluminum tank containing 9 gallons of fuel. The in-tank fuel gauge is visible to both pilots. The wing is covered with 3.6oz polyfiber fabric skin.

The flaps can be set to 3 different positions with a maximum extension of 35 degrees. There are two strong aluminum uprights and a universal joint which allows the wings to be folded back for road transport. The employed alloys are of the 2024-6061/t6 type. All nuts and bolts are of aircraft quality. All the engineering documentation concerning load tests and studies was completed with the aid of sophisticated programs such as the French Catia (aerospace) and the American Nastran and is available on request.

4.3.5 Empennage

The tail (vertical fin and horizontal fins) is cruciform and consists of welded tubing covered with a fabric skin. The rudder is connected to a swivel tail wheel for ease of taxiing. The left elevator incorporates the mechanical trim surface. The horizontal fins with attached elevators can be folded upwards for storage or transport by trailer. Ample control surface area provides positive control about all axes.

4.3.6 Landing Gear

The Savage uses the classic conventional landing gear arrangement (tail wheel). The main gear wheels are fitted with independently controlled hydraulic toe brakes. Landing shock absorption is provided by standard aircraft elastic cord design with a steel safety cable to prevent over-extension. The tail wheel is equipped with a self release mechanism which allows it to swivel freely to reduce the turning radius.

Two large tundra type low-pressure tires can be fitted to allow rough terrain operations (optional).

4.3.7 Cabin

Cabin seating is a tandem arrangement. Each seat is equipped with a four point seat belt. Solo flight is only permitted from the front seat. Maximum baggage weight is 44 lbs.

4.3.8 Flight and Cockpit Control

4.3.9

4.3.10 Left Side

- Dual Throttles
- One Trim Lever
- One Flap Lever

On The Floor

- Fuel On/Off Valve (Under Pilot Seat-left side)
- Dual Rudder And Brake Pedals
- Dual Control Sticks
- Fuel Drain Valve (Under Passenger Seat-right side)

On The Panel

- ELT Remote Switch (optional)
- Master Switch
- Magneto Switch
- Starter Switch
- Engine Choke
- Radio Master Switch (optional)
- Comm. Switch (Optional)
- 12 Volt Accessory outlet switch (Optional)
- Cabin Heat (Optional)

Instruments

- Airspeed Indicator
- Vertical Speed Indicator
- Altimeter
- Compass
- Slip Indicator
- Oil Pressure Indicator
- Oil Temperature Indicator
- Cylinder Head Temp Indicator
- Tachometer
- Volt Meter (optional)

5 Limitations

5.1 Introduction

Section 5 includes operating limitations, instrument markings, and basic placards necessary for the safe operation of the airplane, engine, aircraft systems, and standard equipment. Observance of these operating limitations is required.

The airplane shall be operated so that all limitations and instructions included in this section are observed.

5.2 Type of Operation

The airplane is equipped for day VFR. Night flight is permitted with appropriately certificated pilot and position lights installed.

No Aerobatics Including Spins.

5.3 Airspeed Limitations

Speed	Mph (Kts)	Remarks
V_{ne} <i>Never Exceed Speed</i>	128 (111)	Do not exceed this speed in any condition.
V_{no} <i>Maximum Structural Cruising Speed</i>	99 (86)	Do not exceed this speed except in smooth air, and then only with caution.
V_a <i>Maneuvering Speed</i>	84 (72)	Do not make full or abrupt control movements above this speed.
V_{fe} <i>Maximum Flap Extended Speed</i>	70 (60)	Do not exceed this speed with flaps down.
V_{so} <i>Stalling Speed Landing Configuration MTOW*</i>	38 (33)	Stalling or minimum steady flight speed in the landing configuration (full flap).

*without vortex generator installed

5.4 Maximum Weights

Maximum Takeoff Weight	1235 lbs	560 kgs
Maximum Landing Weight	1235 lbs	560 kgs

5.5 Power Plant Limitations

SEE ENGINE MANUAL

5.6 Other Limitations

5.6.1 Approved Maneuvers

No Aerobatic Maneuvers Including Spins.

5.6.2 Smoking

No Smoking Is Permitted Inside The Cabin.

5.6.3 Solo flight from front seat only (according to the CG calculation)

5.6.4 Limitations Table

Ambient Temperature For Engine Start	Maximum 120°F (50°C)
	Minimum -13°F (-25°C)
Maximum Ambient Temperature for Operation	120°F (50°C) for MTOW
Maximum Speed With Door Open	70 mph (61 kts)
Maximum Number of Occupants	2
Maximum Crosswind Component	18 mph (16 kts)
Maximum Baggage Weight	44 lbs (20kgs)
Maximum Load Factors	Limit: +6 -3

6 Weight and Balance

6.1 Introduction

The Center of Gravity (C.G.) on an airplane is the point at which the plane would hang in balance, were it suspended in midair*. This point is determined by weighting the airplane empty and then calculating the center of gravity. The empty airplane center of gravity location is then expressed in inches from a datum line (an arbitrary point). This will remain a fixed position unless the empty weight is altered. If that occurs, a new empty weight C.G. will have to be calculated.

Loading the airplane with fuel, people, baggage, and other accessories also alters the C.G. Therefore, the payload placed in the airplane has to be calculated to determine a new C.G. for the loaded airplane. The Empty Airplane Weight and Balance C.G. information is completed by an engineer and is a part of an airplane's permanent documents. The C.G. Range is a part of this data. It is expressed as Forward C.G. Limit and Aft C.G. Limit. The airplane's Loaded C.G. must fall somewhere between these two limits to insure that the airplane can be balanced safely during flight with the trim or flight controls. Operating outside of these limits will reduce the control authority of the flight controls and induce instability. C.G. and C.G. Range Limits are expressed in inches from the datum line. On the Savage airplane it is the back face of the propeller.

Attention to total aircraft weight is part of the calculation.

The Weight and Balance data is to remain on board the airplane for all flight operations.

6.2 CG Data

To determine the airplane's Loaded C.G. it is necessary to know the following data:

- Airplane Empty Weight (obtained from W&B Document);
- Basic Empty Weight C.G. and Moment (obtained from W&B Document);
- Payload Weight (fuel, pilot, passenger, and baggage weights are determined by the pilot);
- Station (distance [arm] between each loaded item and the datum line);
- Moment (each payload weight multiplied by its arm).

The engineering contractor determined that the Forward C.G. Limit and Aft C.G. Limit is between **74.0 – 80.7** in from the datum line.

1 inch=2,54 cm. limit in cm :**188-205**

The Datum Line is the rear face of the propeller.

6.3 CG Calculations

Place the leveled airplane with all three tires on the scales.

*To level the airplane, place the elevator in the horizontal position.

Proceed with the weighting and then record the weight exerted on each wheel scale. Calculate the moment by multiplying the scale weight of each wheel multiplied by its arm (distance in inches from the datum line) and record.

6.4 Equipment List

Description	Mfg	Model	Serial No.	Part No.
Engine	Rotax	912ULS		
Propeller	tonini	GT-130		GT-2/182/
Airspeed Indicator	York Avionics			
Slip Indicator	York Avionics			510
Altimeter	York Avionics	A7		320
VSI	York Avionics	109		40
Tachometer	Star Co.	8181839		
CHT Temp Guage	Star Co.	8182191		
Oil Pressure	Star Co.	8181846		
Oil Temp	Star Co.	8181849		
Compass	Airpath			
ELT (optional)	Americorp	AK450		

6.5 CG Work Form

(example)

EMPTY WEIGHT (Includes Oil)			
Description	Weight	Arm	Moment
Main Landing Gear L	306.25	60.62	18564.875
Main Landing Gear R	306.25	60.62	18564.875
Pilot	0	66.90	0
Fuel	0	75.98	0
Passenger	0	99.61	0
Baggage Compartment	0	120.87	0
Parachute	0	144.87	0
Tail Wheel	56	233.46	13073.76
Totals	668.5		50203.51
Aircraft Gross Weight Limit 1235 lbs			
Moment /Weight=CG			75.10
Datum Location-Rear Face of Propeller			
Acceptable CG Range		74.0 - 80.9	
Engine METO 100 HP /12=8.4 Gallons			
Savage Classic Serial Number 0121			10/4/2007
MOST FORWARD			
Description	Weight	Arm	Moment
Main Landing Gear L	306.25	60.62	18564.875
Main Landing Gear R	306.25	60.62	18564.875
Pilot	170	66.90	11373
Fuel 8.4 Gals	50.4	75.98	3829.392
Passenger	0	99.61	0
Baggage Compartment	8	120.87	966.96
Parachute	0	144.87	0
Tail Wheel	56	233.46	13073.76
Totals	896.9		66372.862
Aircraft Gross Weight Limit 1235 lbs			
Moment /Weight=CG			74.00
Datum Location-Rear Face of Propeller			
Acceptable CG Range		74.0 - 80.9	

IMPORTANT: Solo may require ballast added to baggage compartment. Complete weight and balance prior to flight.

MOST REARWARD			
Description	Weight	Arm	Moment
Main Landing Gear L	306.25	60.62	18564.875
Main Landing Gear R	306.25	60.62	18564.875
Pilot	170	66.90	11373
Fuel 18 Gallons	108	75.98	8205.84
Passenger	170	99.61	16933.7
Baggage Compartment	45	120.87	5439.15
Parachute	0	144.87	0
Tail Wheel	56	233.46	13073.76
Totals	1161.5		92155.2
Aircraft Gross Weight Limit 1235 lbs			
Moment /Weight=CG			79.34
Datum Location-Rear Face of Propeller			
Acceptable CG Range		74.0 - 80.9	
Savage Classic Serial Number 0121			
			10/4/2007

6.6 Method

1. Multiply each item's weight times its arm in inches to find the moment. Record each on its respective line.
2. Add all the weights and moments and record each on its respective total line.
3. Divide the total moment by the total weight and the result is the C.G. Index in inches from the datum line.
4. Determine that the airplane's Loaded C.G. falls within the applicable limits (Forward C.G. Limits and Aft C.G. Limits).

7 Performance

7.1 Stalls

7.1.1 Landing Stall Speeds

Flap Setting	Zero	Flaps' 1 st Position – Takeoff	Flaps' 2 nd Position – Landing
V _{s0} MTOW*	43 mph (37 kts)	41 mph (36 kts)	38 mph (33 kts)

*without vortex generator

7.1.2 Stall Indication

Aircraft buffeting will announce an impending stall.

7.2 Takeoff and Landing Distances

Operating on asphalt runway	
Typical Takeoff distance	360 FT
Typical Landing distance	340 FT
Operating on short grass runway	
Typical Takeoff distance	400 FT
Typical landing distance	295 FT

The information above, are very general and according to a typical configuration of the aircraft.

Combination of long grass, tailwind and air density, can substantially affect the takeoff distance and landing.

7.3 Maximum Crosswind Component for Takeoff

The Maximum Crosswind Component for Takeoff is 18 mph (16 kts) (experts only).

7.4 Cruising Flight at sea level

RPM	Power	Speed
4000	40%	79 mph (69 kts)
4400	50%	90 mph (78 kts)
4800	65%	99 mph (86 kts)
5000	75%	104 mph (90 kts)

Note: Air density will affect the engine power and the aerodynamic performance of the plane.

7.5 Service Ceiling

14,400 ft.

7.6 Climb

The best angle of climb speed is 65 mph at maximum takeoff power. Best gradient is enhanced with flaps selected to first flap position.

Climb Flaps Up:	Mph (Kts)
Normal	68 (59)
Best Rate of Climb	70 (61)
Best Angle of Climb*	65 (56)

***Note:** Best obstacle clearance gradient is with takeoff flaps extended (first position) but do not use longer than necessary as prolonged slow speeds may cause excessive engine temperatures.

7.7 RPM

Maximum RPM For all Operations		5800
Full Throttle Static RPM	Not Above	5500
	Not Under	5200

7.8 Fuel Consumption

See engine manual.

8 Emergency Procedures

8.1 Introduction

Section 8 provides a checklist and other procedures for coping with emergencies that may occur. Emergencies caused by system malfunctions are rare if proper preflight inspections and maintenance are practiced. En route weather emergencies can be minimized or eliminated by careful flight planning. Good judgment is necessary when unexpected weather or other circumstances are encountered that might jeopardize safety of flight. However, should an emergency arise, the basic guidelines outlined in this section should be considered and applied as necessary to correct the problem.

8.2 Airspeeds for Emergency Operation

Engine Failure after Takeoff	62 mph (54 kts)
Maneuvering Speed (at all weights)	84 mph (73 kts)
Maximum Glide Distance, Still Air	66-70 mph (57-61 kts)
Precautionary Landing Approach with Engine Power	53 mph (46 kts)
Landing Approach Without Engine Power	Landing Flaps Up 70 mph (61 kts)
	Landing Flaps Down 56 mph (49 kts)

Note: A slightly higher airspeed may increase gliding distance if gliding into the wind. Use a slightly lower airspeed if gliding downwind.

8.3 Engine Failures

8.3.1 Engine Failure during Takeoff Run

1. Throttle – IDLE
2. Brakes – APPLY
3. Ignition Switches – OFF
4. Master Switch – OFF

8.3.2 Engine Failure Immediately After Takeoff

1. Move Control Stick FORWARD and maintain an airspeed of 62 MPH (54 KTS).
2. Fuel Shutoff Valve – OFF
3. Ignition Switches – OFF
4. Wing Flaps – As Required
5. Master Switch – OFF

Note: A slightly higher airspeed may give better distance over the ground if gliding into the wind and a slightly lower speed if gliding downwind.

8.4 Airstart Procedures

8.4.1 Windmilling Airstart

Turn on the Fuel and Ignition with the Propeller Rotating.

8.4.2 Electric Starter Airstart

DO NOT ENGAGE STARTER IF PROPELLER IS ROTATING.

REPEAT STEPS 1 – 9 BELOW AS NECESSARY WHILE OBSERVING ZERO PROPELLER RPM.

1. Ignition Switches – OFF
2. Stop Propeller Rotation (windmilling) by reducing airspeed as necessary, taking care about the decreasing of the indicated airspeed since flying at low speed with the engine switched off could cause a potential "risk" of stall.
3. Establish Glide – 66 – 70mph 57-61 kts
4. Fuel – ON
5. Fuel Pump – ON
6. Master Switch – ON
7. Ignition Switches – ON
8. Starter Button – DEPRESS
9. Throttle – ADJUST

Note: The engine cools quickly with the propeller stopped. Choke may be needed to start if time between restart is longer. After restart, do no increase RPM to Max Power RPM until engine temperatures are in range unless safety of flight dictates otherwise.

8.5 Fires

8.5.1 Fire during Start on Ground

1. Cranking – Continue cranking to suck the flames and accumulated fuel through the carburetor and into the engine combustion chambers.

IF ENGINE STARTS

2. Power – 2500rpm
3. Fuel – OFF (to allow engine to empty carburetor)
4. Engine – Inspect for damage.

IF ENGINE FAILS TO START

2. Cranking – Continue in an effort to obtain a start. If the engine still fails to start after 15 seconds, shut off fuel and continue to crank to drain carburetor.
3. Extinguish Fire
4. Master Switch – OFF
5. Ignition Switch – OFF
6. Fuel Pump Switch – OFF
7. Fuel Shutoff Valve – OFF
8. Allow only authorized maintenance personnel to inspect, repair, and/or replace damaged components or wiring before conducting another flight.

8.5.2 Engine Fire during Flight

1. Throttle – Closed
2. Fuel Shutoff Valve – OFF
3. Mag Switches – OFF
4. Master Switch – OFF
5. Fuel Pump Switch – OFF
6. Cabin Air – OFF
7. Airspeed – Maintain normal glide airspeed. The fire should extinguish after the fuel is consumed in the engine compartment. If the fire doesn't extinguish and altitude permits, increase the glide speed without exceeding V_{ne} to an airspeed which will provide an incombustible mixture. If that fails, side slip the airplane to keep the fire away from the cabin and fuselage.
8. Forced Landing – Execute Power off Landing.

8.5.3 Electrical Fire during Flight

1. Master Switch – OFF
2. All Other Switches – OFF
3. Cabin Door/Air Vents – OPEN

If fire appears out and electrical power is necessary for continuance of flight:

4. Master Switch – ON
5. Fuses – Check for Faulty Circuit. Do not reset fuses in a faulty circuit.
6. Radio/Electrical Switches – ON one at a time, pausing after each switch selection until short circuit is found. Leave faulty switch off.
7. If unable to isolate faulty circuit, turn master switch OFF.
8. Land as soon as possible to inspect for damage and repair.

8.5.4 Cabin Fire

1. Master Switch – OFF
2. Cabin Door and Vents – CLOSED (to reduce air circulation)
3. Fire – EXTINGUISH (if able)
4. Land as soon as possible, inspect for damage, and repair as necessary.

8.6 Precautionary and Forced Landing

8.6.1 In-flight Engine Failure

1. Airspeed – at least 56 mph (49 kts) on the approach (flaps down).
2. Fuel Shutoff Valve – OFF
3. Fuel Pump – OFF
4. Ignition Switches – OFF
5. Wing Flaps – As required
6. Master Switch – OFF
7. Touchdown – Three Point
8. Brakes – As required.

8.6.2 Off-Field Precautionary Landing with Power

1. Initial Airspeed – 53 mph (46 kts)
2. Wing Flaps – 2nd Stage
3. Fuel Pump – ON
4. Selected Field – FLY OVER and note terrain and obstructions.
5. Radio and Electrical switches – ON
6. Wing Flaps – FULL (on final approach)
7. Touchdown – Three Point.
8. Ignition Switch – OFF
9. Brakes – As Required.

8.6.3 Ditching – Water Landing

1. Radio – Transmit MAYDAY on Emergency Frequency advising location and problem.
2. Heavy Objects – Secure
3. Approach – In high winds and Seas land INTO the wind.
4. Flaps – Select Flaps' 2nd Position.
5. Touchdown – Minimum Airspeed, Tail low.
6. Face – Cushion at touchdown with folded coat or cushion.
7. Egress – Release seatbelts. Evacuate through the door. (Consider opening the door before touchdown to prevent it from jamming during landing).
8. Life Vests – INFLATE.

NOTE: Attempt to touch down with the tail first at minimum airspeed. When the main gear contacts the water it will cause a pitching moment. If the pitching moment is severe enough, it will upset the airplane to the inverted position. Time permitting; take the ELT with you to aid in rescue.

8.6.4 Maximum Glide

For Maximum Distance in Still Air: 66-70 mph (57-61 kts).

To maximize distance with a headwind, increase glide speed by approximately one-third of the wind's velocity.

8.7 Other Procedures

8.7.1 Recovery from an Inadvertent Spin

Inadvertent spins are unlikely and should one occur, proceed as follows:

1. Throttle – IDLE
2. Ailerons – NEUTRALIZE
3. Rudder – OPPOSITE RUDDER until rotation stops
4. AFTER ROTATION STOPS – neutralize the rudder. Reduce back pressure on the flight control stick to regain flying speed. As soon as the airplane is flying again (which will happen very quickly with proper control inputs) begin a smooth pull up with back pressure on the flight control stick to level flight.
5. Level Flight, Set Power.

8.7.2 Ignition Malfunction

A sudden engine roughness or misfiring is usually evidence of an ignition problem. Switching from both on to alternately switching to each system off will identify which system is malfunctioning. Leave the switch to the good system and land at the nearest suitable airport for repairs.

8.7.3 Low Oil Pressure

Situation 1: **A rapid drop** from normal indicated pressure to zero (0) indication.

1. Smell for a noticeable oil odor.
2. Open cabin air vents.
3. Look for signs of escaping oil on cowls, windscreen, and wing surface.
4. If there is a strong odor of oil and noticeable escaping oil, reduce power to a minimum to sustain level flight and proceed to the nearest landing area.
5. Be prepared to make an emergency landing should the engine fail.

Situation 2: **Gradual reduction in oil pressure** below observed normal position.

1. Observe oil temperature indications.
2. If oil temperature is higher than normal indications, and all other engine functions are normal, proceed to the nearest landing area, land, and check oil levels and external oil system for leaks.
3. If oil level is low, top-off to full mark on dipstick.
4. Allow the engine to cool, then start the engine, bringing it up to full power while observing oil pressure.
5. If oil pressure readings are normal, proceed with flight, and observe oil pressure and temperature indications.
6. If the oil pressure remains below normal indications during and after a power run-up, have the engine checked by authorized maintenance personnel.

9 Normal Operations

9.1 Introduction

Section 9 provides checklists and other procedures for the conduct of normal operations.

9.2 Normal Operating Speeds

The following speeds are based on a maximum weight of 1235 lbs and may be used for any lesser weight.

Takeoff		Mph (Kts)
	Takeoff, 1 st Stage Flap	44 (38)
	Short Field Takeoff, 2nd Stage Flap	41 (36)
	When Clear of Obstacles, retract flaps, then climb at v_y	70 (61)
Climb, Flaps Up		Mph (Kts)
	Normal	68 (59)
	Best Rate of Climb, at a low altitude	70 (61)
	Note: Best obstacle clearance gradient is with 1 st stage flaps; but do not maintain this condition for longer than necessary as this may cause excessive engine temperatures.	
Landing Approach (MTOW)		Mph (Kts)
	Normal Approach, Flaps Full	53 (46)
	Short Field Approach, Flaps Full	50 (43)
Missing Approach (go around)		Mph (Kts)
	Apply full power, allow speed to increase to	62 (54)
	Retract flap to 1 st stage	
	Then, retract flap fully and continue to climb at or above	70 (61)
	Maximum Recommended Turbulent Air Penetration Speed	99 (86)
	Maximum Demonstrated Crosswind Velocity	18 (16)

9.3 Checklist and Procedures

9.3.1 Preflight Inspection

The aircraft should be inspected in prior to flight by using the subsequent checklists and in the sequence shown in the following diagram:

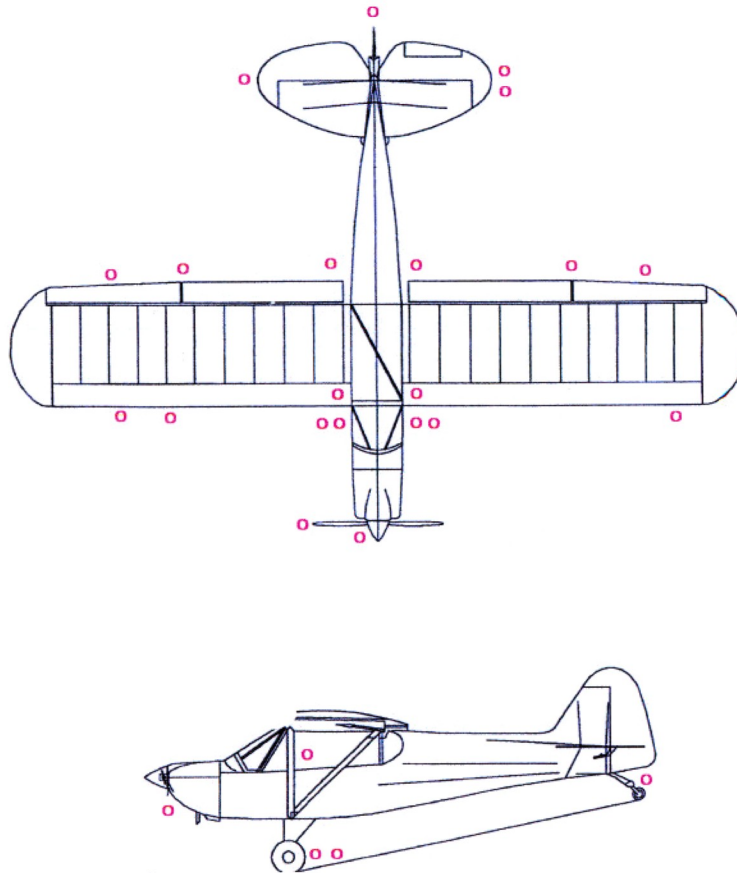

Note: Visually check the airplane for general condition during the walk around inspection. In cold weather remove even small accumulations of frost, ice, or snow on the wing, tail, and control surfaces. Also, make sure that the control rods and cables are free of ice and move freely.

Preflight Inspection Checklist:

1 – Fuel		
1	Fuel Quantity	Visually check fuel level in tank.
2	Water Contamination	Before first flight of the day and after each refueling, drain a small quantity of fuel from the fuel drain valve and check for water and sediment.
3	Fuel Filler Cap	Check security.

2 – Empennage		
1	Tailwheel	Check
2	Control Surfaces	Check freedom of movement and security.

3 – Right Wing – Trailing Edge		
1	Aileron	Check freedom of movement and security.
2	Flap	Check security.
3	Control Rods and Cables	Check aileron, flap control nuts and bolts, and flap control rod for security. Check rod ends for freedom of rotation and excessive movement.

4 – Pitot Tubes		
1	Static and Dynamic Source	Remove cup and check for blockage.

5- Right Wing		
1	Wing	Check for damage.
2	Main Wheel and Tire	Check for security, proper inflation, wear, or damage.
3	Wing Mounting Bolts and Struts	Check for security.

6 – Nose		
1	Propeller and Spinner	Check both for security and damage.
2	Cowling	Remove and check engine mount pressure gauge for pressure, security of engine components, systems, security of engine mounts, spark plugs, wiring, fuel lines, and also for fluid leaks.
3	Engine Oil, Coolant Level	Check fluid levels and top off as necessary. Clean up any fluid spills.
4	Cowling	Replace and tighten quick fasteners. Check security of cowling.

7 – Left Wing		
1	Main Wheel and Tire	Check wheel and tire for security, proper inflation, and damage.
2	Wing Mount Bolts and Struts	Check Security.
3	Wing	Check for damage.
4	Wing	Check vortex generator installation (optional)

8 – Left Wing – Trailing Edge		
1	Aileron	Check freedom of movement and security.
2	Flap	Check security.
3	Control Rods and Cables	Check aileron, flap control nuts and bolts, and flap control rod for security. Check rod ends for freedom of rotation and excessive movement.

9 – Cabin		
1	Flight Manual	VERIFY ON BOARD
2	Control Lock	REMOVE
3	Ignition Switches	OFF
4	Master Switch	OFF
5	Fuel Shutoff Valve	ON
6	Seatbelts and Shoulder Harnesses	Check for condition and security.
7	Aileron Cable Mountings	Check for free rotation, excessive movement, and nuts and bolts for security.
8	Elevator Torque Tube Mounting and Rod End	Check for free rotation, excessive movement, bolt and nut for security to aircraft structure.
9	Rudder/Tailwheel Steering Cables	Check security and freedom of movement.
10	Flap Control	Check freedom of movement and security of bolts.
11	Throttle Controls	Check for full and free travel.
12	Rudder Pedals and Toe Brakes	Check freedom of travel on both and verify brake pressure.

9.3.2 Before Starting Engine

1	Preflight Inspection	COMPLETE
2	Seatbelts & Harness	ADJUST & LOCK
3	Fuel Shutoff Valve	ON
4	Radio/Intercom	OFF
5	Brakes	TEST & SET
6	Instruments	Set for Current Conditions

9.3.3 Starting Engine – Cold Engine

1	Carburetor Heat	COLD (optional)
2	Choke	ON
3	Throttle	CLOSED
4	Fuel Boost Pump	ON (optional)
5	Propeller Area	CLEAR
6	Master Switch	ON
7	Ignition Switches	ON
8	Stick	FULL BACK
9	Start	TURN SWITCH
Note: The engine will not start if it is cranking below 600rpm.		
Note: Immediately after engine start, set throttle idle speed to 1600rpm.		
11	Engine Instruments	CHECK
12	Choke	CLOSED

Note: Verify adequate engine oil pressure within 10 seconds of startup. If no oil pressure indicated shut down the engine immediately and determine the cause.

9.3.4 Starting Engine – Hot Engine

Proceed in the same manner as starting a cold engine; however, do not open the choke and open the throttle 1/4.

9.3.5 Warm-Up and Functional Check

Warm up the engine with a fast idle speed of 1600 to 2500rpm until the oil temperature reaches 122°F (50°C). During this phase the cooling is insufficient due to reduced cooling airflow (only the prop wash is providing airflow on the ground). It is advisable not to shorten the warm-up time by running the engine at a higher rpm. The aircraft should be pointed into the wind to permit more cooling air. As soon as the oil reaches 122°F (50°C), continue with the Before Takeoff Check.

9.3.6 Before Takeoff

1	Brakes	CHECK
2	Cabin Doors	CLOSED AND LATCHED
3	Flight Controls	FREE AND CORRECT
4	Flight Instruments	SET
5	Fuel Shutoff Valve	ON
6	Elevator Trim	NEUTRAL
7	Flaps	SET FOR TAKEOFF
8	Ignition Check	<p>Set Throttle at 4000rpm. Maintain this engine speed for 10 seconds, then:</p> <ul style="list-style-type: none"> • Switch #1 ignition OFF and watch rpm drop. • Switch No. 1 ignition ON and #2 ignition OFF and watch rpm drop. • Switch #2 ignition back to on. <p>RPM drop should not exceed 300rpm on either system. If rpm drop exceeds 300rpm; shut down the engine and determine the reason.</p>
<p>Note: During the check with one system operating, the inactive spark plugs tend to load up. If an unsatisfactory check on one of the systems, attempt to clean the plugs by running the engine with both ignitions ON for a few seconds and then recheck the unsatisfactory system.</p>		
9	Power Check	Increase the throttle slowly to MAXIMUM STATIC RPM of 5500rpm.
<p>Note: The wind can affect static rpm, so there will be some variation due to wind conditions. However, if the rpm is found to be more than 300 rpm lower than normal, the engine should be examined to determine the cause before flight.</p>		
10	Idle Check	Throttle to the idle position and check that the engine runs smoothly. A too low idle speed or a rough running engine is not acceptable for safe flight and the condition must be corrected before flight.
11	Carburetor Heat	Optional, however, if customer orders this equipment, there is not pilot input required.

9.4 Taxi Procedures

9.4.1 Introduction

Normal Taxi is conducted with throttle tail wheel, brakes, and flight controls. The proper application and coordination of these various controls makes taxiing easier. Brakes and rudder pedals are designed to operate in conjunction. Begin the initial taxi by gently checking the brakes after taxi roll begins before normal taxi speed is attained.

The swiveling tail wheel provides the pilot with better ground control during taxi operations. Differential braking can be used to assist in taxi turns. Differential braking can only be used when the airplane is rolling. All taxi operations must be carried out under the lowest speed to ensure the landing gear is not overstressed. Check to make sure there are no obstacles that might interfere with the taxi operation. Normal straight ahead vision over the nose cowling is good in the three point attitude so normal taxi operations will require very little S turning to provide adequate vision.

9.4.2 Taxiing into a Headwind

In normal conditions (insignificant wind) or with a headwind, taxi with flight control stick fully aft to ensure the tail wheel remains firmly in contact with the ground to provide positive ground control.

9.4.3 Taxiing Downwind

Keep the control stick in the forward position to avoid the wind lifting the tail and causing a nose over.

9.4.4 Taxiing with a Crosswind

Point the control stick into the wind to hold the wings level and balanced. Maintain directional control by compensating with the rudder and brakes.

9.5 Takeoff

The takeoff method depends on various factors: obstacles, wind direction and velocity, takeoff surface, outside temperature, air density and weight.

Note: The airspeed indicator will not provide an accurate indication at speeds under 25mph – 22kts.

9.5.1 At Normal Takeoff MTOW

Check for airplanes in the final approach area before positioning on the runway. Once the airplane is aligned with the runway centerline, increase power slowly and smoothly to maximum takeoff power. The airplane will accelerate quickly. When airspeed increases to approximately 22mph, sufficient positive flight control will exist to smoothly raise the tail to takeoff altitude. When takeoff airspeed is reached, the airplane will takeoff with a gentle increase in back pressure on the flight control stick. This occurs at about 44mph (first stage flap). Accelerate over the runway centerline to climb speed and retract the flaps.

Normal Takeoff		
1	Wing Flaps	1st Stage
2	Carburetor Heat (Optional)	COLD – if present
3	Throttle	FULL OPEN
4	Elevator Control	Gently lift the tail
5	Best Climb Speed Vy	70 mph (61 kts)
6	At Top of Climb, Fuel Boost Pump	OFF – if present

9.5.2 Shortfield Takeoff

Extend the flaps to the second position (35 degrees). Stop on the runway aligned with runway centerline. Hold the flight control stick full aft. While holding full brakes increase the throttle to maximum takeoff power. Release the brakes; raise the tail to a tail low takeoff altitude. Lift off will occur at an approximate airspeed of 40mph. Level off above the runway and accelerate and retract the flaps to the first position. Continue accelerating to normal climb speed, initiate climb and complete flap retraction and reduce to normal climb power.

Short Field Takeoff		
1	Wing Flaps	2nd Stage
2	Carburetor Heat (Optional)	COLD – if present
3	Brakes	APPLY
4	Throttle	FULL OPEN
5	Brakes	RELEASE
6	Elevator Control	LIFT THE TAIL
7	Take Off Speed	41 mph (36 kts)

9.5.3 Obstacle Takeoff

Same procedure as for short field takeoff except after takeoff retract the flaps to the 1st flap position and accelerate to best angle of climb speed (V_x) at 65mph. Maintain max takeoff power and best angle of climb airspeed until clear of the obstacle. When clear reduce climb altitude to normal climb altitude, accelerate to normal climb speed and complete flap retraction and reduce to normal climb power.

9.5.4 Crosswind Takeoff

A crosswind takeoff is accomplished with the flaps retracted to clean configuration so that the takeoff will occur at a higher airspeed. A higher airspeed will help ensure that ground contact will not occur after liftoff. Also, a higher airspeed will increase flight control authority. Use normal takeoff procedures except flaps retracted; maintain direction with rudder and aileron input. Maintain 3 point altitude until positive flight control airspeed is attained. When this airspeed is attained, raise the tail a little higher than for a normal takeoff attitude. This is accomplished by holding forward pressure on the flight control stick. This puts extra weight (via air load) on the main wheels which helps maintain adequate ground control while accelerating to a higher than normal lift off airspeed. When the desired liftoff airspeed is attained use positive back pressure on the control stick when rotating to ensure positive lift off. Accelerate to a slightly higher climb speed than normal until clear of ground turbulence. Track over the runway centerline by crabbing into the wind enough to correct for wind drift.

9.5.5 After Takeoff

When a safe altitude and airspeed have been attained, reduce engine power to climb power while maintaining normal climb airspeed, retract the flaps and trim as necessary.

9.5.6 Enroute Climb

The best angle of climb speed is 65 mph (56 kts) at Maximum Takeoff Power. Best gradient is enhanced with flaps selected to 1st flap position. You could choose both : Vx or Vy

1	Airspeed Vy	70 mph (61 kts)
2	Throttle	FULL OPEN
Note: During climb, monitor the water and oil temperatures to avoid exceeding their limits. The aircraft has been tested to ensure adequate cooling in a climb, therefore any excessive readings may indicate a malfunction of the indicator. However, if a overheat indication occurs, decrease the rate of climb in order to increase the airspeed for improved cooling. Monitor the indicator to verify a change in temperature.		

9.5.7 Cruise at sea level

Note: Do not exceed the Maximum Continuous Power (5500rpm).

RPM	Power	Speed
4000	40%	79 mph (69 kts)
4400	50%	90 mph (78 kts)
4800	65%	99 mph (86 kts)
5000	75%	104 mph (90 kts)

9.6 Landing Procedures

9.6.1 Before Landing

Note: A protracted descent at minimal engine speed could induce rapid cooling of the engine which can cause ice to form in the carburetor. To prevent carburetor ice, the engine should be operated at nominal power setting periodically.

1	Seatbelts & Harnesses	ADJUST AND LOCK
2	Carburetor Heat (optional)	ON- if present
3	Fuel Boost Pump (optional)	ON - if present

9.6.2 Normal Landing at MTOW

Maintain normal power-off approach with flaps selected to 2nd flap position while maintaining 53mph (46kts) airspeed. After the flare is initiated, the touchdown will occur at about 40mph. After landing, maintain full aft position of the flight control stick and brake careful. Retract the flaps after landing.

1	Airspeed	53 mph (46 kts)
2	Wing Flaps	2nd FLAP POSITION
3	Touchdown	THREE POINT
4	Braking	MINIMUM

9.6.3 Short Field Landing at MTOW

Use normal approach airspeed for the 2nd flap position until short final then reduce airspeed to 50mph to arrive at the runway threshold at a minimum safe airspeed. After the flare is initiated, the touchdown will occur at approximately 40mph close to a full stall three point landing. Maintain the flight control stick in full aft position and brake as necessary to stop on the runway. Retract the flaps after the landing is complete.

1	Airspeed	50 mph (43 kts)
2	Wing Flaps	FULL DOWN (below 70 mph (61 kts))
3	Power	REDUCE to idle as obstacle is cleared
4	Touchdown	THREE POINT
5	Brakes	APPLY AS REQUIRED
6	Wing Flaps	RETRACT AFTER THE STOP

9.6.4 Crosswind Landing

The most effective method to prevent drift in a light aircraft is the low-wing method. This technique keeps the longitudinal axis of the airplane aligned with both the runway centerline and the direction of motion throughout the approach and touchdown.

There are three factors that will cause the longitudinal axis and the direction to be misaligned during touchdown; drifting, crabbing, or a combination of both. To land with one of these conditions or a combination of both existing at the time of touchdown is to induce a side load on the landing gear and better than even chance in the loss of control of the airplane (ground loop). Damage to the aircraft due to excessive side loads or loss of control is a definite possibility. Pilot attention to drift and airplane longitudinal alignment is paramount in every landing.

In light crosswinds, the traditional full stall three point landing can be accomplished safely. However, in more forceful crosswinds a wheel landing is the preferred method. This is accomplished in the clean configuration (flaps up) and at a higher than normal touchdown speed. Using this method where the aircraft is flown onto the runway increases flight control authority and it affords better options in the event the landing has to be aborted and a go-around instituted. Increase the touchdown landing speed up to ten percent.

9.6.5 Balked Landing

Max Takeoff Power should be applied immediately as soon as the decision to go-around is made, if the airplane is already configured with landing flaps set to 2nd flap position. After Max Power is applied, level off, accelerate, and retract the flaps to 1st flap position. When flaps are retracted to 1st flap position and normal climb airspeed is attained, rotate to normal climb altitude and continue climb while retracting flaps to clean configuration. When aircraft is cleaned up and established in normal climb, reduce to normal climb power.

1	Throttle	MAXIMUM POWER
2	Carburetor Heat	OFF
3	Wing Flaps	RETRACT to 1st FLAP POSITION
4	Airspeed	66-68 mph (57-59 kts) until clear of obstacles

9.6.6 Stall Characteristics

The Savage Airplane is stable around the pitch axis. The natural tendency after the wing stalls is to pitch nose down. The wing uses the 4412 airfoil which is noted for its early warning of an impending stall and the benign stall characteristics after it occurs. Consequently, there is nothing unusual in the stall or recovery.

9.6.7 Stall Recovery

The natural tendency to recover built into the airplane would allow the airplane to recover on its own merit if it is properly trimmed. However, the proper use of the flight controls can greatly enhance the recovery and minimize the loss of altitude just as improper use of the flight controls can impede it.

Early recovery is dependent upon early recognition. At the first indications of an impending stall, apply Max Power, decrease the angle-of-attack with the flight control stick and level the wings if the aircraft is in a turn to speed up the recovery and minimize the loss of altitude.

Smooth control inputs in precise amounts are necessary to minimize altitude loss. Misuse of the controls can impede the recovery or could induce a secondary stall.

Note: The flight controls remain functional in all phases of flight including stalls. Flight control pressures are light and responsive. At higher airspeeds the controls are more sensitive to misuse of pilot inputs. This is true in any aircraft. Therefore, excessive extension of one or more of the flight control surfaces into the air stream at a high airspeed might cause the airplane to exceed the load index. Avoid exaggerated control movements for a smooth and comfortable flight. The rudder and elevators are in the propeller slipstream and retain a higher degree of authority than the ailerons through all airspeed regimes.

9.6.8 After Landing

1	Wing Flaps	UP
2	Fuel Boost Pump (Optional)	OFF
3	Carburetor Heat (Optional)	OFF

10 Aircraft Handing and Servicing

10.1 Fueling Safety Precautions

Never fuel the aircraft in an enclosed area or where vapors could collect. DO NOT SMOKE or allow open flames or sparks in the vicinity during fueling operations. Never add fuel while the engine is running.

Never refuel an aircraft if the possibility exists of fuel spilling on a hot engine, hot components, or lexans.

Use only approved fuel containers and never transport fuel in an unsafe manner.

Always check for fuel contamination. Contamination is a major cause of engine failure. The best place to avoid fuel contamination is at the source. Once contaminated fuel is on board the airplane a very hazardous situation exists. Use a clean safety approved storage container. Do not overfill the container, and allow room in the container for expansion.

Always use a static ground during refueling of the aircraft. Connect the static ground to the grounding point next to the refueling port before refueling and remove the static ground after the fuel cap is replaced and refueling terminated.

Before first flight of the day, and after each refueling, use a sampler cup and drain a small quantity of fuel from the fuel drain valve and check for water, sediment, and other contaminants.

SEE THE ENGINE MANUAL FOR THE FUEL TYPE APPROVED.

10.2 Filling the Fuel Tanks

When fueling from a pump remember to reduce the fuel dispense rate when the fuel tank is almost full and withdraw the fuel nozzle out of the tank far enough so the nozzle is not immersed in the fuel. This is applicable to the last gallon or gallon and half to be pumped. Otherwise, a siphoning action could be generated through the vent system until the fuel level is below the vent. In other words, don't overfill the fuel tank by pumping fuel into the expansion area of the fuel tank. If you fill up the expansion area, approximately a gallon or so will vent onto the ramp and the EPA and others will be unhappy. Protect carefully the lexan from any contact with the fuel. The fuel will damage in few second the lexan if not protected. Caution to static electricity, ground the airplane before to refill the fuel.

10.3 Propeller Care

A full throttle run-up over loose gravel is especially harmful to propeller tips. When takeoffs must be made over a gravel surface, it is very important that the throttle be advanced slowly. This allows the airplane to start rolling before high RPM is developed. Consequently, the gravel will tend to be blown behind the propeller rather than sucked into it. When unavoidable small nicks appear in the propeller, they should be corrected immediately.

10.4 Securing the Airplane

1. Turn off Radio Master Switch and all Electrical Equipment.
2. Determine Engine Temperatures are in Range.
3. Turn off Ignition Switch.
4. Turn off Master Switch.
5. If aircraft is to remain parked outside, secure the flight controls, chock the main wheels, and secure the aircraft with tie-downs.
6. Remove key from the ignition switch

10.5 Noise Abatement

Increased emphasis on improving the quality of our environment requires renewed effort on the part of all pilots to minimize the effect of airplane noise on the public.

As pilots, we can demonstrate our concern for environmental improvement by application of the following procedures:

- At altitudes under 2000ft, avoid flying in close proximity to houses or over parks and recreational areas;
- During approach to or departure from an airport, the climb after takeoff and descent for landing should be made so as to avoid prolonged flight at low altitude near noise sensitive areas.

10.6 Engine Shutdown

1. Turn off the Ignition Switches, one mag at a time;
2. Turn off the Master Switch.

10.7 Starting the Engine from an External Power Source

When it is necessary to start the engine from an external power source:

1. Remove Battery Access Door;
2. Place jumper leads directly on battery terminals, ensuring positive to positive and negative to negative;
3. Start as for normal operation;
4. After engine starts, remove external jumper leads and close battery access door.

Note: Wheels must be chocked, ensure propeller is clear, and ensure a qualified operator is in the pilot seat.

11 Required Placards and Markings

11.1 Airspeed Indication Range Markings

Marking	Range (mph/kts)	Operational Significance
White Arc	38-70 (33-61)	FLAP OPERATING RANGE Bottom of white arc is MTOW V_{s0} * in landing configuration. Upper limit of white arc is Max Speed permissible with flaps extended.
Green Arc	43-99 (37-86)	Normal operating range. Lower limit is maximum weight V_s with flaps retracted. Upper limit is max structural cruising speed.
Yellow Arc	99-127 (86-110)	Operations must be conducted with caution and only in smooth air.
Red Line	128 (111)	V_{ne}

*without vortex generator installed

11.2 Passenger Warning

This aircraft was manufactured in accordance with Light Sport Aircraft airworthiness standards and does not conform to standard category airworthiness requirements.

11.3 Aerobatic Statement

No Aerobatics.

11.4 Spin Statement

No Intentional Spins.

12 Supplemental Flight Training Information

12.1 Design Philosophy

The Savage was intended as a Piper Cub substitute in Europe because the purchase price for an imported Cub was very expensive.

The name Savage was chosen early in the development phase because it describes (in Europe) the passion for a type of flying that is unhurried and relaxed. The Savage regales the days of yesteryear when all light aircraft were equipped with conventional landing gear (tail wheel). Zlin Aviation s.r.o. plans to keep it that way. The typical mission this airplane was designed to perform would be encumbered with a tricycle gear.

The Savage is very conventional and conservative just as the Cub Light Plane it imitates. It is easy to fly and maintain. It doesn't have any unusual flight characteristics and is well mannered in all flight regimes. Consequently, this supplement will deal mostly with other things that will enhance knowledge about some aspect of the airplane, equipment, operational suggestions, safety, and/or regulations that might help the pilot maximize the safe utilization of the airplane.

12.2 Revisions

If there is a need to revise any data in the Pilot Operating Handbook which includes this Supplement, the owner operator will be furnished with a revision and it will be the owner's responsibility to insure it is inserted correctly and then remove the old information.

12.3 Other Landing Gear

The Savage comes equipped with float and ski fittings incorporated as standard equipment on the airframe. Also, tundra tires are available as an option.

12.4 Ground Transport

The airframe incorporates folding wings and folding horizontal tail surfaces to allow for trailer transport.(20-30 minutes of work for 2 man)

12.5 Other Equipment Necessary for Flight

Depending on the area of operation, the FARs may require the airplane to be equipped with avionics (ELT, Radio, Transponder, etc.), so as to comply with airspace limitations. In some cases, the pilot may have to qualify too, depending on type of pilot license or rating.

12.6 Engine Differences

For some pilots the operation of this engine will be nothing new. It has been around for a number of years and has proven itself on a variety of aircraft. However, there will be a lot of you who are transitioning to Light Sport Aircraft who have never operated anything but a Continental or a Lycoming engine. Consequently, there are some differences that you must be aware of to operate it safely. The operation of the engine is detailed in the Engine Owner's Manual. The engine is geared so that it produces the equivalent horse power as a Continental O-200 with about 100lbs less weight. It is liquid cooled, air cooled, and oil cooled. As an example, checking the oil quantity is different if you are used to a Continental or Lycoming engine. Check the manual for the procedure.

12.7 Engine Mount

The optional engine mount is pressurized with an inert gas and a pressure gauge is mounted in the engine compartment. Checking the pressure before each flight is a part of the preflight. Loss of pressure indicates a crack in the mount.

12.8 Landing Flap Takeoffs

The Pilot Operating Manual suggests using flaps in the 2nd Flap Position (landing flaps) for only two types of takeoffs. The first one is for a Short Field Takeoff and the second is for a Soft Field Takeoff.

The logic behind this is to help transfer the weight of the airplane to the wings as early as possible. The airplane is operating in ground effect during takeoff so it is a benefit under these circumstances. However, it is important after lift off to level off just above the surface, accelerate, and retract the flaps to the 1st Flap Position (takeoff flaps), continue acceleration to climb airspeed, then climb and retract remaining flaps on schedule.

12.9 Side Slips

The flight controls have generous surface area so slips are easy to perform. Proper use of this method of controlling rate of descent and airspeed can be very useful in certain circumstances. Rate of descent and airspeed can be adjusted very quickly.

12.10 Emergency Checklists

The most important thing to remember when using a checklist is to continue to fly the airplane. This can't be over emphasized. Engine failure right after takeoff won't allow much time for anything except checking the essentials (ignition, fuel, etc.) The point is to fly the airplane and then do the checklist.

13. Optional Appendix

13.01 Vortex generator

Vortex generator, is an optional that increase the stoll characteristics of the plane. Installation of vortex generator must be done only by personnel authorized from Zlin Aviation s.r.o.

Characteristic with vortex generator installed.

MTOW 1235 lbs

The stall speed (no engine applied) full flap decreases of about 3 mph , the airplane stalls at about 35 mph. The stall speed with no flap and in the same configuration decreases of about 2,5 mph with an IAS of 40,5 mph.

The cruise speed has not changes.

The controls on different axis are better than without vortex installed and have not contra-indications.

The stall due to higher nose attitude is sharper and we recommended to pay attention to stalls at very low altitude above ground.

The recovering technique of the stall is the same like the Savage without vortex installed.

We recommend to use full power and to reduce immediately the high nose attitude to recover from the stall.

The flare with no engine is easier with the vortex installed due to a better control on the pitch axle.

Intentionally left blank

13 Feedback Form

Zlin Aviation s.r.o.

Customer Feedback Form

Please return via mail to savage.ulm@tiscali.it

Manual Title: _____

Date of Issue: _____

Section, Chapter, Paragraph Affected: _____

You're Feedback: _____

Now Reads: _____

Should Read: _____

You're Name: _____

Address: _____

City: _____ State: _____ Zip: _____

Tel: _____ Cell: _____ Fax: _____

E-mail address: _____

Intentionally left blank

14 Malfunction or Defect Report Form

Zlin Aviation s.r.o.

Customer Feedback Form

Please return via mail to savage.ulm@tiscali.it

Manual Title: _____

Date of Issue: _____

Section, Chapter, Paragraph Affected: _____

You're Feedback: _____

Now Reads: _____

Should Read: _____

You're Name: _____

Address: _____

City: _____ State: _____ Zip: _____

Tel: _____ Cell: _____ Fax: _____

E-mail address: _____

LOAD FACTORS

INFORMATION FOR PILOTS

Angle of wings to Horizontal	Example	Load Factor Required
0 degrees		1
(Gentle 10 degrees Blank)		1.01
20 degrees		1.06
30 degrees		1.15
40 degrees (Medium Blank)		1.31
50 degrees		1.56
60 degrees		2.0
70 degrees		2.92
80 degrees		5.75

The following table shows the minimum speeds necessary to safely execute banked turns based on the 38 mph stalling speed :

Angle of Wings to Horizontal	% Increase in Normal Stalling Speed	Actual Stalling Speed
0 degrees	0	38.0 mph
10 degrees	.5	38.2 mph
20 degrees	3.0	39.2 mph
30 degrees	7.0	40.7 mph
40 degrees	14.4	43.5 mph
50 degrees	25.0	47.5 mph
60 degrees	41.4	53.7 mph
70 degrees	71.0	65.0 mph
80 degrees	240.0	91.2 mph

From the above table it will be seen that, because of the extra load factor added to the wings in order to make a proper banked turn, the speed must be increased to keep from stalling out in the banked turn.

As a final word, in the small commercial airplane, a pilot can withstand more than the airplane; therefore, it is suggested that the pilot should not depend entirely on his feeling for proper maneuvering. Let the statistics be a basis upon which he builds his safe flying habits. In rough weather let the rule be *The rougher the weather the slower the airplane should be flown*. Gusts place excessive loads on the airplane structures. Because of this, it is good practice to reduce the maneuvering loads to a minimum so that, with the additional momentary gust loading, the airplane will not be loaded beyond a safe point.

TEN COMMANDMENTS For Safe Flying

1. THOU SHALL NOT BECOME AIRBORNE WITHOUT CHECKING THY FUEL SUPPLY : It only takes a few minutes to gas up . . . it may save you a forced landing.
2. THOU SHALL NOT TAXI WITH CARELESSNESS : Taxi slowly and make S turns to clear the area in front of the nose. Know the proper use of the controls for taxiing in a strong wind.
3. THOU SHALL EVER TAKE HEED UNTO AIR TRAFFIC RULES : Keep a constant lookout for other aircraft. Follow the rules so that pilots of other planes will know what you are going to do.
4. THOU SHALL NOT MAKE FLAT TURNS : This is particularly important when making power-off turns. You steer with the ailerons, not the rudder.
5. THOU SHALL MAINTAIN THY SPEED LEST THE EARTH ARISE AND SMITE THEE : Don't be fooled by the increase in ground speed resulting from a downwind turn. Keep sufficient airspeed.
6. THOU SHALL NOT LET THY CONFIDENCE EXCEED THY ABILITY : Don't attempt instrument flying in adverse weather conditions unless you have the proper training and the necessary instruments. Instrument flying is a highly developed science. Don't pioneer.
7. THOU SHALL MAKE USE OF THY CARBURETOR HEATER : The carburetor heater is your friend. Know when to use it. Remember that it's easier to prevent ice in the carburetor than to eliminate it after it has formed.
8. THOU SHALL NOT PERFORM AEROBATICS AT LOW ALTITUDES : Aerobatics started near the ground may be completed six feet under the ground. There's safety in altitude.
9. THOU SHALL NOT ALLOW INDECISION IN THY JUDGMENT : Be certain! You can't afford to make errors of judgment. "I think I can make it" is on the list of famous last words.
10. THOU SHALL KNOW ALWAYS-THE GOOD PILOT IS THE SAFE PILOT: It's better to be an old pilot than a bold pilot.

*Courtesy of
Piper Aircraft Corporation*

Lock Haven, Penna.