

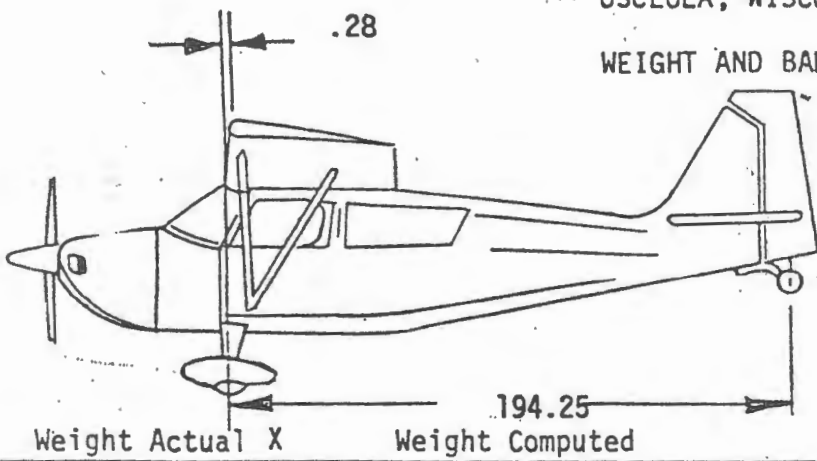

Champion Model No. 7ECA  
 Serial No. \_\_\_\_\_  
 Identification No. \_\_\_\_\_  
 Date \_\_\_\_\_  
 Signed \_\_\_\_\_

WEIGHT AND BALANCE



Aircraft Leveling Means: Drop plumb line from wing leading edge so that it is 10.19 inches forward of front face fuselage wing strut fitting.

Weight Actual X      Weight Computed

Main Wheel Weight	1046.00		
Tail Wheel Weight	59.00		
Total Aircraft Weight Plus Oil	1105.00		
$L.G. = \frac{(59.00)(194.25)}{(1105.00)} - .28 = 10.09 \text{ In Aft L.E.}$			
$\text{Moment} = (1105.00)(10.09) = 11151 \text{ In.LF}$			
Aircraft Weight with Oil	1105.00	10.09	11151
Fuel	-11.25	-36	+408
Gallon Unuseable Fuel	+6.00	+15	+90
Total Aircraft Empty Weight Less Fuel Plus 1 Gallon Unuseable Fuel	1099.75	10.59	11649

APPROVED EQUIPMENT LIST

Sec. No.	Item	Wt.	Arm	Spec. No.	Item	Wt.	Arm
	O-235-K2C Lycoming Engine (dry) w/Start. & Alt.	246	-40	X	407c Fire Extinguisher	5	-5
4g	Spinner Assembly	4	-61	X	408b Rear Seat Heater	2	-9
1	Propeller Sensenich 72CK58-0	28	-58	X	409c Emergency Locator Beacon		
2j	Carb. Air Box Assembly	1	-33	X	Turn & Bank Ind.	2	5
3h	Carb. Air Filter	1	-45	X	Rate of Climb Ind.	1	-4
1e	Starter Assembly	18	-46	X	Horizon Gyro	2	-5
7i	Mixture Control Install.	1	-10	X	Directional Gyro	3	-5
8e	Oil Cooler & Lines	3	-29	X	Clock	--	--
3a	Gallon Fuel System	39	20	X	O.A.T. Gauge	--	--
0i	Mufflers & Stacks Install.	15	-42	X	King KX 145/KI 205 Nav, Com		
1c	Vacuum Pump Install.	3	-28		Inst. Per Dwg. 7-1527	7	15
1i	Hyd. Brake & Wheel Ass'y				Cabin Speaker Inst. Per Dwg. 7-1293	1	33
	600 x 6, 4 Ply Tires	29	0	X	Accelerometer (G-Meter) 3"	1	-5
2g	Scott 3200 Tailwheel	8	191	X	Cabin Lite-Rheostat Inst. Per Dwg. 7-1524	1	22
5k	Wheel Pants	14	0	X	Oil Quick Drain Inst. Per Dwg. 7-1530	--	--
7f	Parking Brake	2	-14	X	Aileron Gap Kit Inst. Per Dwg. 4-1477	--	--
2f	Hyd. Brake Sys. Cleveland	2	-10	X	Greenhouse Roof Inst. Per Dwg. 7-1268	3	24
3g	Position Lights	1	90	X	UBG-16	1.5	-5
1r	Battery Inst. 12V Rebat	23	-26				
1s	Battery Inst. 12V Gill	23	-26	X			
1j	Alt. & Volt. Reg. 60 Amp	12	-50	X			
1h	Landing Light	1	-53	X			
1c	Rotating Beacon	2	62	X			
1n	Adjustable Front Seat, Cushions & Belts	15	16	X			
1o	Rear Seat, Cushions & Belts	13	47	X			
1p	Wide Rear Seat	18	47				