

AeroDynamic Aviation

Twin Comanche PA30

Preflight Check

Cabin

Controls	Free
Avionics Master	Off
Landing Gear Selector	Down
Mag Switches	Off
Master Switch	On
Fuel Quantity Gauges	Check
Wing Flaps	Lower
Lights & Pitot Heat	Check
Master Switch	Off
Documents:	Onboard

- Airworthiness certificate
- Registration
- Operating Limitations
- Weight & Balance
- Garmin 430 manual

Airworthiness Items

Annual Inspection	12 cal. months
100 hour (if required)	Check tach
Transponder	24 cal. months
ELT (check battery date)	12 cal. months
ADs	Complied With
VOR check (IFR)	30 days
Altimeter (IFR)	24 cal. months

Walk Around Inspection

Exterior

Overall Condition, No Damage	Check
------------------------------	-------

Right Wing

Control Surfaces	Check
Wing Tip & Lights	Check
Fuel Tanks & Caps	Check, Secure
Fuel Vents & Overflow Drains	Clear
Tie Down & Chock	Remove
Main Gear Strut	Proper Inflation
Tire	Check
Oil (6-8 qts)	Check Level
Dip Stick and Oil Door	Secure
Air Inlets	Clear

Walk Around Inspection

Right Wing (cont'd)

Propeller	Check
Propeller Area	Clear of Debris
Cowling	Secure

Nose Section

Windshield	Clean
Heater & Air Inlet	Clear
Nose Gear Strut	Proper Inflation
Tire	Check

Left Wing

Oil (6-8 qts)	Check Level
Dip Stick and Oil Door	Secure
Air Inlets	Clear
Propeller	Check
Propeller Area	Clear of Debris
Cowling	Secure
Fuel Tanks & Caps	Check, Secure
Fuel Vents & Overflow Drains	Clear
Tie Down & Chock	Remove
Main Gear Strut	Proper Inflation
Tire	Check
Stall Warning Switch	Free
Pitot Tube	Free & Clear
Wing Tip & Lights	Check
Control Surfaces	Check

Fuselage & Empennage

Fuel sump	Drain x4
Static Vents	Clear
Control Surfaces	Check
Navigation Lights	Check
Antennas	Check
Dorsal Fin Air Inlet	Clear
Tie Downs	Remove
Tow Bar	Stowed
Baggage Door	Secure
Hobbs & Tach	Record
Sunshades	Remove

AeroDynamic Aviation

Twin Comanche PA30

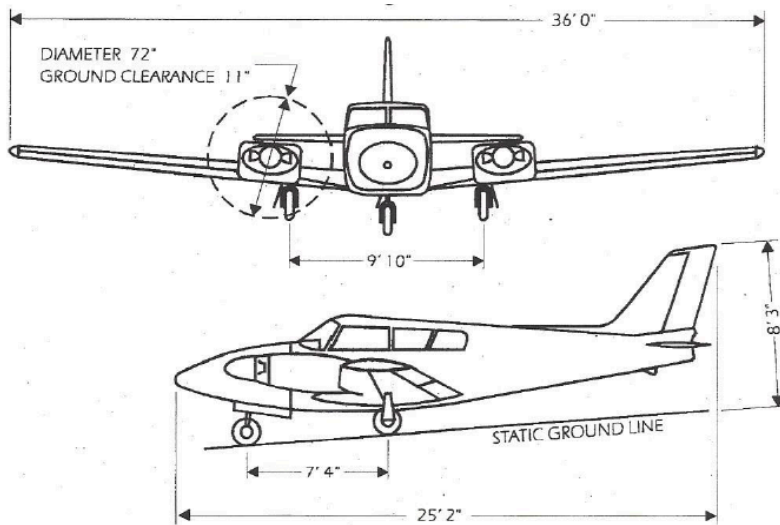
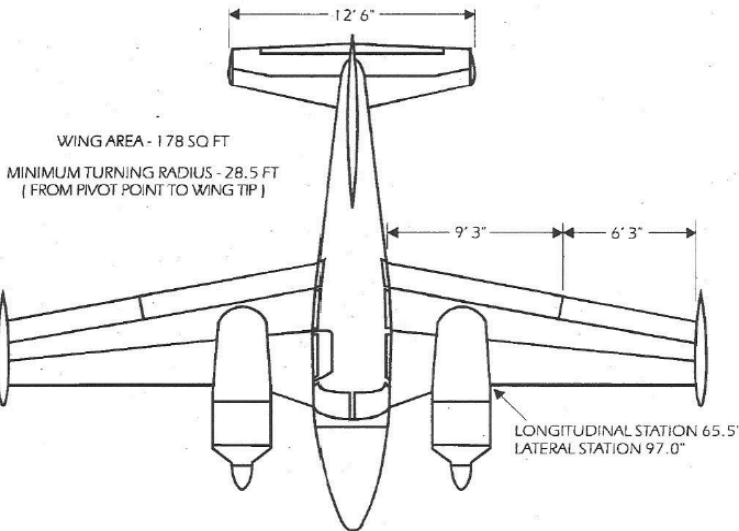

Cabin Dimensions

Cabin Length	9 ft.
Cabin Height	47 in.
Cabin Width	45 in.
Cabin Entry Height	32 in.
Cabin Entry Width	34 in.

Weights

Maximum Takeoff	3600 lb.
Maximum Landing	3600 lb.
Maximum Baggage	250 lb.
Max in 5th & 6th Seats	235 lb.

Twin Comanche N40DA

Empty Weight	2376.6 lb
Empty Arm	82.59"
Empty Moment	196273.9
Useful Load	1223 lb.
Serial #	30-904

Capacities

Main Fuel Tanks	60 gal total, 54 usable
Aux Fuel Tanks	30 gal total, 30 usable
Fuel Grade	91/96 - 100LL
Oil Grade	(100W) MIL-L-22851C
Oil Capacity (each engine)	8 US qts.
Normal Oil (each engine)	6-7 qts.
Tire Pressure (all tires)	42 psi

Limitations (at max weight)

ME Service Ceiling	18,600
SE Service Ceiling	5,800
ME Absolute Ceiling	20,000
SE Absolute Ceiling	7,100
Max approved altitude	20,000
Flap settings	0°, 15° & 27°
Propeller Low Pitch	12°, Feather 78°